



Umbosintwini, South Africa, 10:15 am

TAMPING RAMMER

NEW



PMR60HN



PMR60RN



PMR70HN



PMR70RN

65kg/143lb

74kg/163lb



PMR40R



PMR60H



PMR60R



PMR68H

40kg/88lb

60kg/132lb

68kg/150lb



PMR70H



PMR70R



PMR75R



PMR85D

70kg/154lb

75kg/165lb

87kg/192lb

TAMPING RAMMER



PMR40R/PMR60H/PMR60R/PMR68H/PMR70H PMR70R/PMR75R/PMR85D

Technical Specification



Model	PMR40R
Engine Type	Robin EH09
Power kw(hp)	2.1(2.8)
Weight kg(lb)	46(101)
Impact Force kN	12.5
Jumping Stroke mm(in)	50-70(2.0-2.8)
Fuel Tank L(US gal)	2.8(0.74)
Shoe Size mm(in)	270x100(10.6x3.9)



Model	PMR60H
Engine Type	Honda GX100
Power Kw(hp)	2.2(3.0)
Weight Kg(lb)	60(132)
Impact Force kN	10.7
Jumping Stroke mm(in)	50-85(2-3.4)
Fuel Tank L(US gal)	2.8(0.74)
Shoe size mm(in)	340x265(13.4x10.4)



Model	PMR60R
Engine Type	Robin EH09
Power Kw(hp)	2.1(2.8)
Weight Kg(lb)	60(132)
Impact Force kN	10.7
Jumping Stroke mm(in)	50-85(2-3.4)
Fuel Tank L(US gal)	2.8(0.74)
Shoe size mm(in)	340x265(13.4x10.4)



Model	PMR68H
Engine Type	Honda GX100
Power Kw(hp)	2.2(3.0)
Weight Kg(lb)	68(150)
Impact Force kN	12.8
Jumping Stroke mm(in)	40-85(1.6-3.4)
Fuel Tank L(US gal)	2.8(0.74)
Shoe size mm(in)	340x285(13.4x11.2)



Model	PMR70R
Engine Type	Robin ER12
Power kw(hp)	2.9(4)
Weight kg(lb)	75(165)
Impact Force kN	13.8
Jumping Stroke mm(in)	40-80(1.6-3.1)
Fuel Tank L(US gal)	3(0.8)
Shoe Size mm(in)	340x285(13.4x11.2)



Model	PMR70H
Engine Type	Honda GXR120
Power kw(hp)	2.7(3.6)
Weight kg(lb)	70(154)
Impact Force kN	13.0
Jumping Stroke mm(in)	40-85(1.6-3.4)
Fuel Tank L(US gal)	2.8(0.74)
Shoe Size mm(in)	340x285(13.4x11.2)



Model	PMR75R
Engine Type	Robin EH12-2D
Power Kw(hp)	3.0(4.0)
Weight Kg(lb)	75(165)
Impact Force kN	13.8
Jumping Stroke mm(in)	40-80(1.6-3.1)
Fuel Tank L(US gal)	2.8(0.74)
Shoe size mm(in)	340x285(13.4x11.2)



Model	PMR85D
Engine Type	Yanmar L48 diesel engine
Power Kw(hp)	3.5(4.8)
Weight Kg(lb)	85(187)
Impact Force kN	18
Jumping Stroke mm(in)	40-80(1.6-3.1)
Fuel Tank L(US gal)	2.8(0.74)
Shoe size mm(in)	340x285(13.4x11.2)

Working Size(mm/in)

Model	A	B	C	D	E
PMR40R	1120/44	345/14	705/28	100/4	270/11
PMR60H	1063/42	345/14	703/28	265/10	340/13
PMR60R	1063/42	345/14	703/28	265/10	340/13
PMR68H	1028/40	345/14	703/28	285/11	340/13
PMR70H	1028/40	345/14	703/28	285/11	340/13
PMR70R	1060/42	410/16	692/27	285/11	340/13
PMR75R	1060/42	410/16	692/27	285/11	340/13
PMR85D	1040/41	410/16	703/28	285/11	340/13

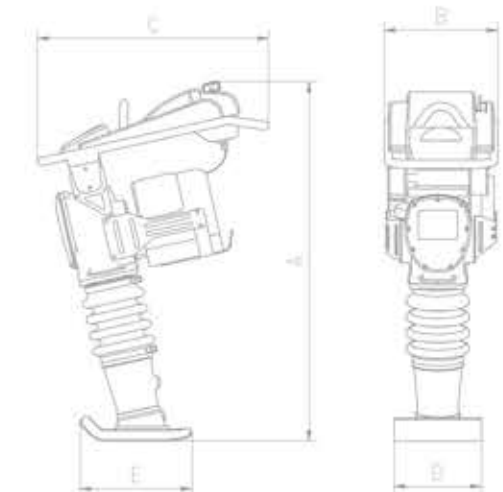

TAMPING RAMMER

PMR60HN/PMR60RN/PMR70HN/PMR70RN



Masterpac four stroke rammers are perfectly balanced to deliver hard hitting compaction as well as operator comfort, delivering low noise and vibration to the operator.



Tachometer for RPM and Hours standard.



Throttle operation with integrated engine shutoff.



Engine protection frame with full wrap around.



Strong cyclone air filter



Optional transport wheel



Convenient roller for easy loading

NEW

Model	PMR60HN	PMR60RN
Engine Type	Honda GXR120	Robin ER12
Power kw(hp)	2.7(3.6)	2.6(3.5)
Weight kg(lb)	65(143)	65(143)
Impact Force kN	12.0	12.0
Jumping Stroke mm(in)	35-80(1.4-3.2)	35-80(1.4-3.2)
Fuel Tank L(Gal)	2.5(0.66)	2.5(0.66)
Shoe Size mm(in)	340x265(13.4x11.2)	340x265(13.4x11.2)

NEW

Model	PMR70HN	PMR70RN
Engine Type	Honda GXR120	Robin ER12
Power kw(hp)	2.7(3.6)	2.6(3.5)
Weight kg(lb)	74(163)	74(163)
Impact Force kN	13.8	13.0
Jumping Stroke mm(in)	40-85(1.6-3.4)	40-80(1.6-3.1)
Fuel Tank L(Gal)	2.5(0.66)	2.5(0.66)
Shoe Size mm(in)	340x285(13.4x11.2)	340x285(13.4x11.2)